

Algas-SDITM
...Innovative liquid vaporizing and gas mixing solutions

ISO 9001
Certified

Stabilaire

Liquid LPG Pump Packages; Models: BS1 through BS3 (5-110 GPM)

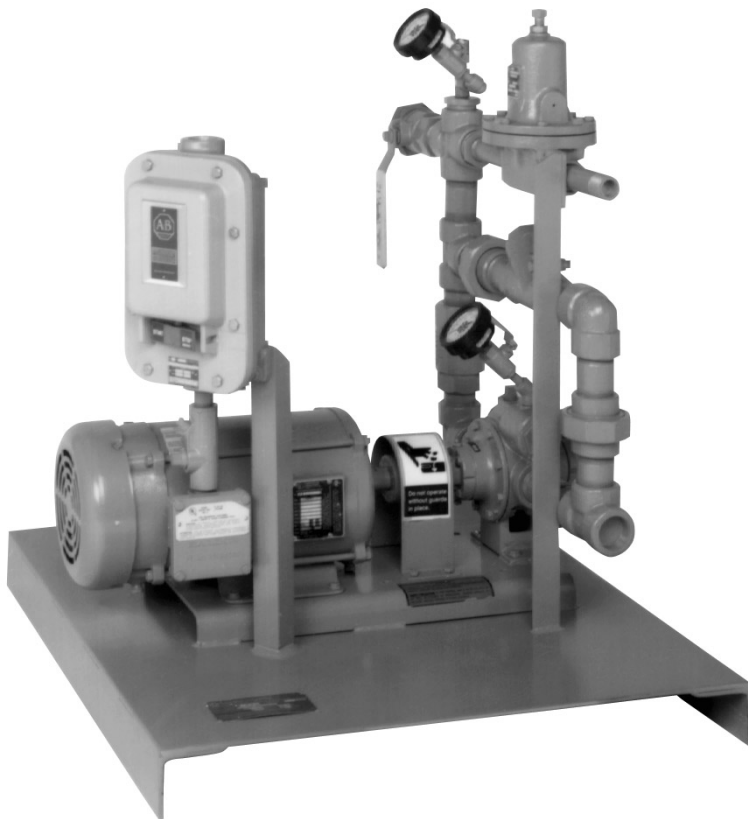

- Fully packaged liquid pressure stabilization system specifically designed to match ASDI's complete line of vaporization and air/gas mixing equipment.
- Complete with bypass line, pressure relief valve, shut-off valves, check valve, and pressure gauges.
- An inlet strainer is provided for field installation.
- Pump motors through 10HP are fitted with manual starters; 15HP and above have magnetic starters. **STABILAIRE**[®] pump systems are factory piped, wired, and tested.
- System designed to meet Class I, Division 1, Group D requirements.

Specifications

Pump Selection Chart																	
Pump Model	Millions of BTU's Per Hour															System Pressure	
	7	14	21	28	42	56	70	84	100	125	150	175	200	225	250		
BS1 - 1HP	■	■															5 & 8 PSI Venturi System 100 PSID
BS1¼ - 2HP			■	■	■	■											
BS1¼ - 3HP						■											
BS1½ - 3HP							■	■	■								
BS2 - 5HP									■	■	■						
BS2 - 7 ½HP										■	■	■	■				
BS3 - 10HP													■	■	■	■	
BS1 - 1HP		■															10 PSI Venturi System 125 PSID
BS1¼ - 3HP			■	■	■												
BS1¼ - 5HP					■	■											
BS1½ - 5HP						■	■	■									
BS2 - 5HP								■									
BS1 - 1HP	■																
BS1¼ - 3HP		■	■	■	■												12 PSI Venturi System 150 PSID
BS1¼ - 5HP					■	■											
BS1½ - 5HP						■	■	■									
BS2 - 7 ½HP								■									
BS2 - 10HP									■	■	■						
BS3 - 15HP											■	■	■	■			
BS3 - 20HP															■	■	

This chart is based on the manufacturer's recommendation of sizing the pump for 2 to 2½ times the actual flow required except for the SC series which do not share this requirement.

Features/Options

- ◆ These positive displacement systems use rotary vane pumps with a built-in over pressure relief valve, designed for continuous use with high reliability.
- ◆ A back pressure control valve provides stable delivery pressure by returning excess pump capacity to the storage tank.
- ◆ Each system is supplied with an explosion proof motor and start/stop station installed to meet Class I, Division 1, Group D requirements.
- ◆ Magnetic starters available for the smaller pumps.
- ◆ The economy operation includes a magnetic starter and pressure switch to minimize the amount of time the pump is in operation reducing wear and tear and saving electricity.

Belt Driven Pump

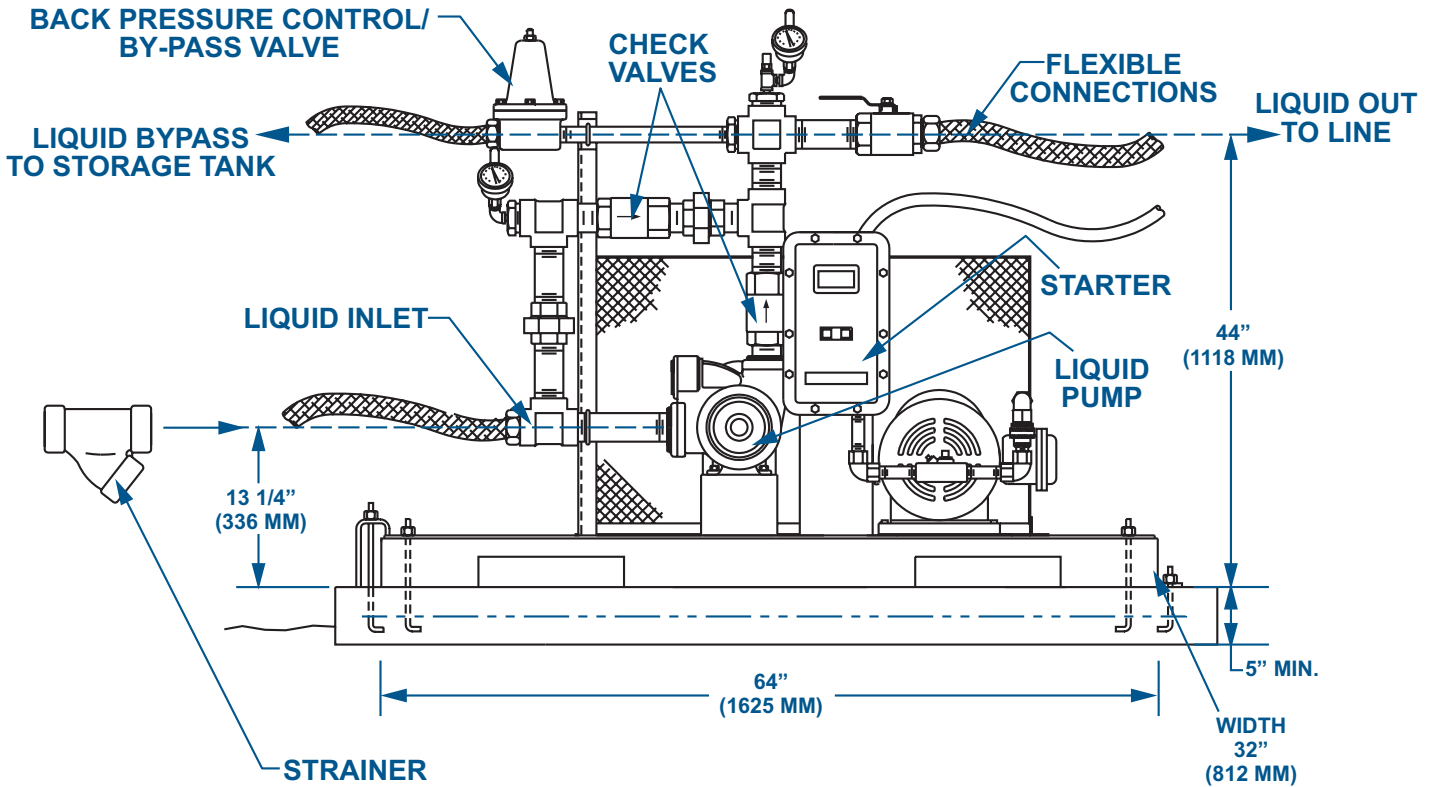

Direct Drive Pump

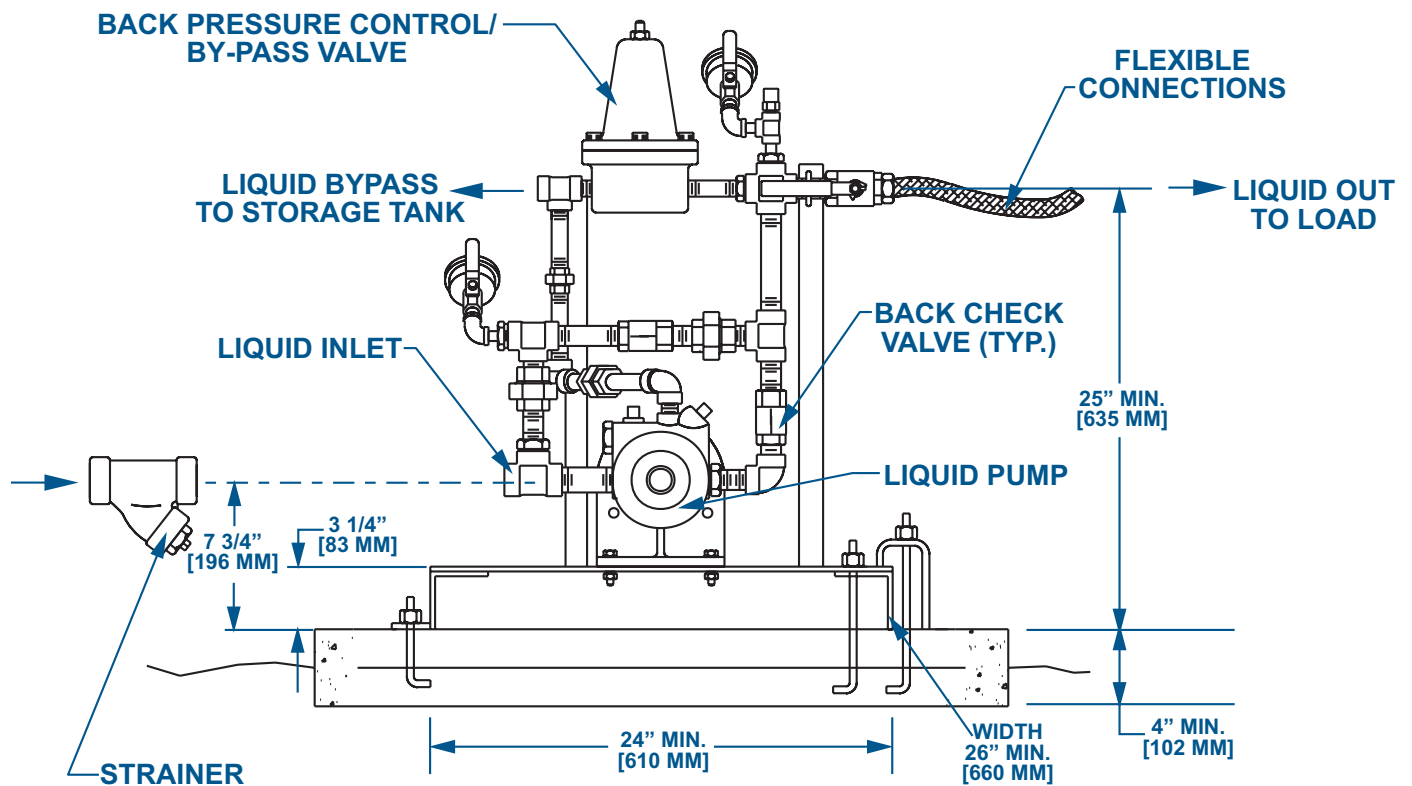

Side Channel Pump

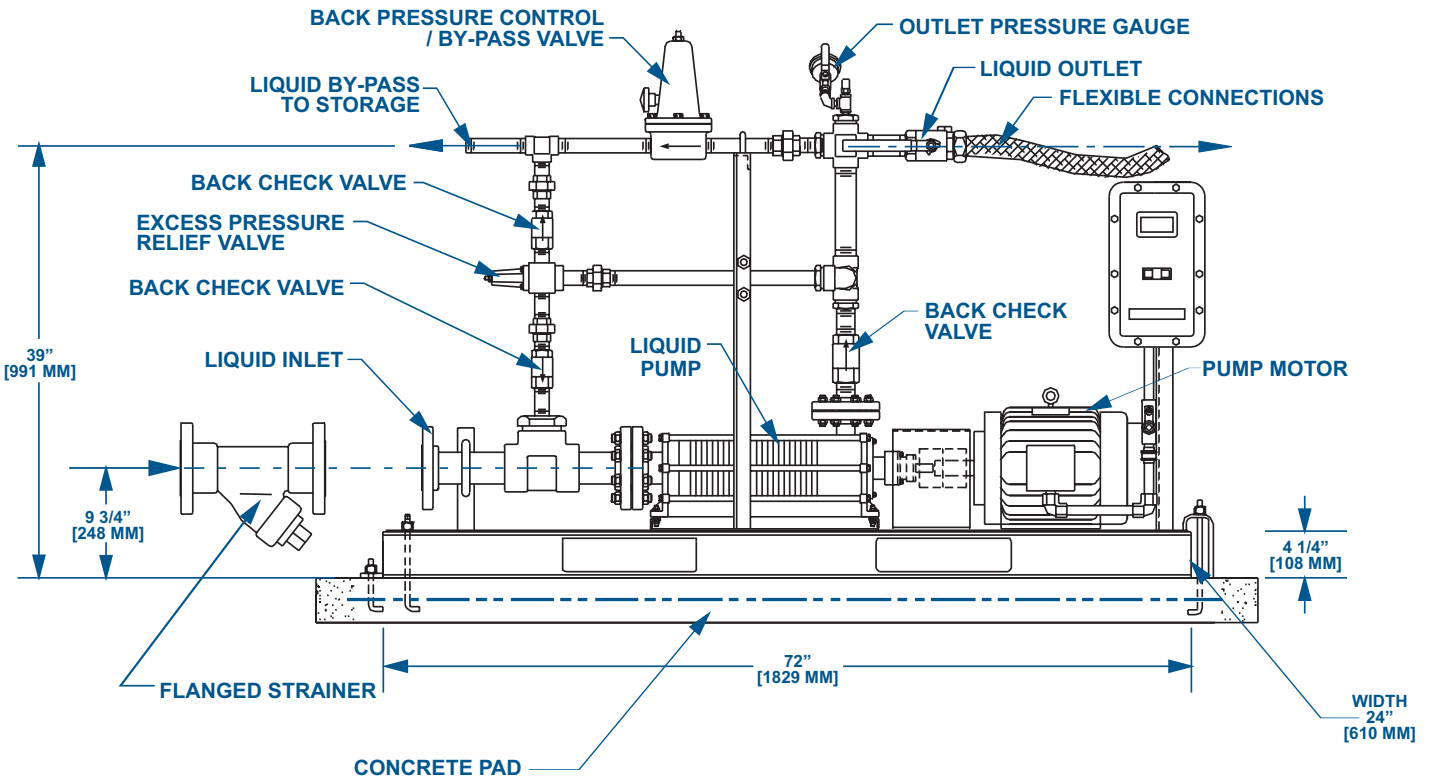

STABILAIRE® is a registered U.S. trademark of **Algas-SDI**.



ISO 9001
Certified

...Innovative liquid vaporizing and gas mixing solutions

Home Office:

1140 NW 46th Street
PO Box 70498
Seattle, Washington 98107 USA

Tel: 206.789.5410
Fax: 206.789.5414

e-mail: sales@algas-sdi.com
internet: www.algas-sdi.com

Beijing Office:

Room A1007 Huibin Office Building
No. 8 Beichen Dong St.
Chaoyang District, Beijing 100101, P.R.C.

Tel: 86.10.64969593, 64993818
Fax: 86.10.64969592, 64993817

e-mail: algasbj@public.east.cn.net

Mexico Office:

Bosque de Alisos number 47-A 5 Piso
Col. Bosques de las Lomas
Mexico D.F. 05120

Tel: 52.5261.8100
Fax: 52.5259.8085

e-mail: algas-sdi@cft.com.mx

Your ASDI distributor:

ECLIPSE™
Innovative Thermal Solutions

Algas • SDI

Form: S0401